

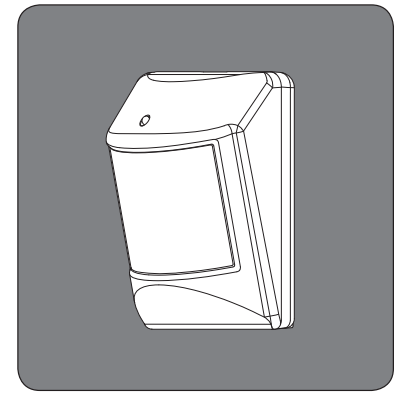

P516-486

Motion Sensor Installation Instructions



Product Overview

- Wireless Z-Wave™ enabled motion sensor
- Detection area is approximately 30 x 39' area (9 x 12 meters)

Product Specifications

- For indoor use only
- 90° wide angle detection pattern
- Features pet immunity setting approximately 50 lbs / 22.7 kilograms
- Operating frequency: 908.42 MHz
- Operation range: Up to 100 feet (30.5 meters) line-of-sight
- Operating temperature: 0° – 49°C, 32° – 120°F
- Provides battery condition feedback
- Battery life approximately 3 years
- Battery type required: 3V Lithium CR123A

Tools Required

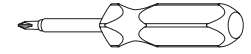

1

Install a Battery in the Motion Sensor

- Lift the tab on top of the Sensor cover and remove the cover (see figure a. below).
- Insert a new 3V CR123A battery into the battery compartment. Observe polarity (see figure b. below).

The Sensor's LED will blink slowly to indicate that the Sensor is connected to power and is not enrolled. If the LED does not blink, check that the battery is new and is inserted with correct polarity.

- After observing the slow blinking LED, replace the Sensor cover (see figure c. below). **Do not press on the lens.**

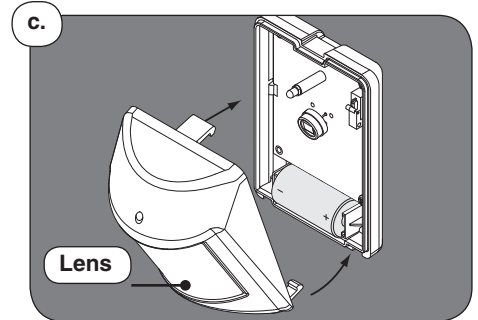
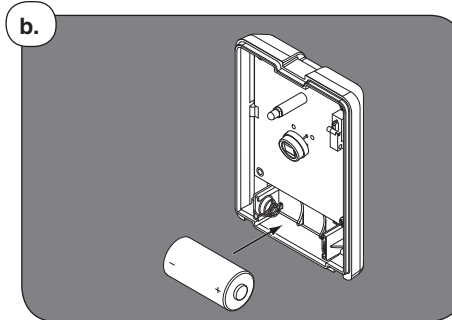
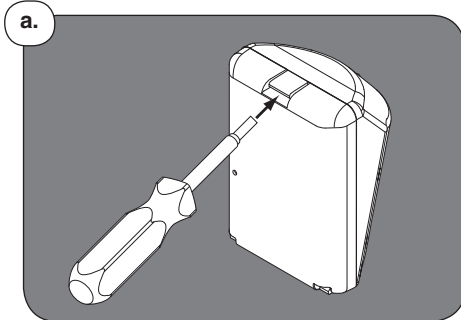

2

Prepare the Nexia Bridge for Enrollment. Choose and follow the easiest option for you shown below.

Battery powered Bridge:

- Disconnect Ethernet and power to the Bridge.
- Install a fresh, high-quality 9-volt battery into the Bridge.
- Move the Bridge to within 6 feet (1.8 meters) of the Sensor. Keep the Bridge in this position during the entire enrollment process.

AC powered Bridge:

- Move the Sensor to the Nexia Bridge for enrollment.
- Keep the Sensor within 6 feet (1.8 meters) of the Nexia Bridge during the entire enrollment process.

For more information, refer to the Nexia Bridge User Guide.



DO NOT plug in Ethernet or power before enrolling!

3

Enroll the Sensor

- Press and release the “+” button on the Bridge. The orange LED will blink slowly to indicate enrollment mode.
The Bridge will remain in enrollment mode for 30 seconds before timeout.
- Use a pin or paper clip to press the program button on the back of the Sensor case.
- During enrollment, the Bridge’s LED will change from slow to rapid blinking.
- When enrollment is successful, the Bridge’s orange LED will light solid, and the Sensor’s LED will turn off.
- If the Bridge LED never blinks rapidly and enrollment mode times out (after 30 seconds), and the Sensor’s LED does not turn off, then repeat step a–d.

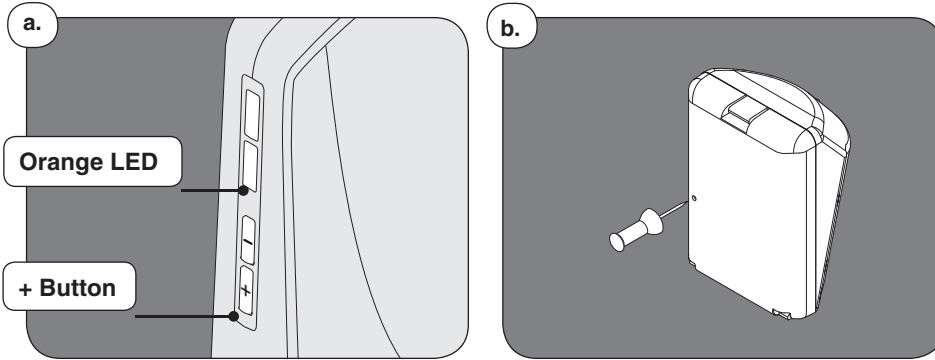

4

Verify the Motion Sensor is added to the Nexia Bridge

! Remove the 9-volt battery from the Nexia Bridge, if installed.

- Connect the Bridge to AC power and Ethernet.
- Login to your online Nexia account.
- Click on “Security & Sensors”, then “Sensors”, then “Setup Device”. (See Figures 1 – 3 below.)

Note: Browser feedback is not immediate. The online display may take 5 seconds to 1 minute to change. Be sure to allow time for the browser to refresh.

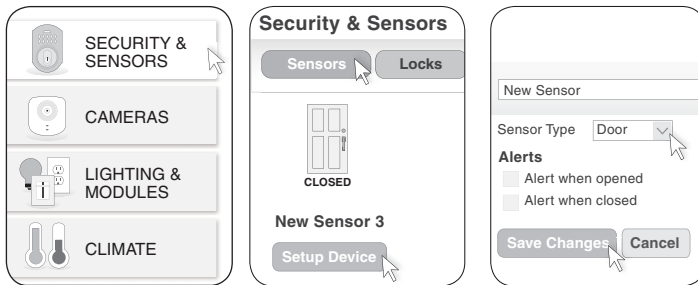

Figure 1

Figure 2

Figure 3

- Check that a “motion detected” condition is indicated on the Nexia portal online display. (Refer to the example above.)

5

Test Tamper Indication (Optional)

- If the Sensor’s cover is removed, the Sensor’s LED will light solid for up to ten (10) seconds, and a “tamper condition” message will be sent to the Nexia Bridge.
- Check that the tamper condition is indicated on the Nexia portal online display. (Refer to the example below.)

Event History

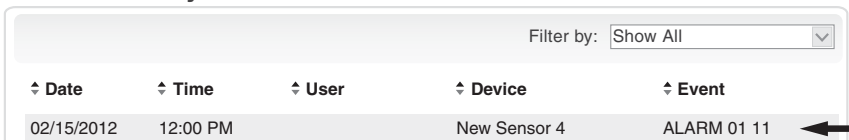

Note: Browser feedback is not immediate. The online display may take 5 seconds to 1 minute to change. Be sure to allow time for the browser to refresh.

6

Determine Motion Sensor Placement

- Place the Sensor so that the detection zone will cover the area to be monitored. (Refer to coverage diagram below.)
- Do not install the Sensor on a metal wall.
- Do not install the Sensor in a location where large metal objects (i.e., kitchen appliances) may limit the wireless signal.
- Avoid placing the Sensor in a location that is facing direct sunlight.
- Avoid placing the Sensor in an area where the temperature may change rapidly.
- Avoid placing the Sensor in an area where air ducts or other considerable airflow is nearby.

Note: An optional Schlage Z-Wave repeater (RP100, RP200) can improve performance.

7

Install the Motion Sensor

- Install the Sensor 6½ to 7½ feet (2 to 2.3 meters) above the floor.
- Attach the Sensor mount to the wall using four screws when mounted against a corner, or two screws when mounted against a flat surface.
- Align the holes on the back of the Sensor with the tabs on the mount. Gently push down on the Sensor to secure it to the mount.

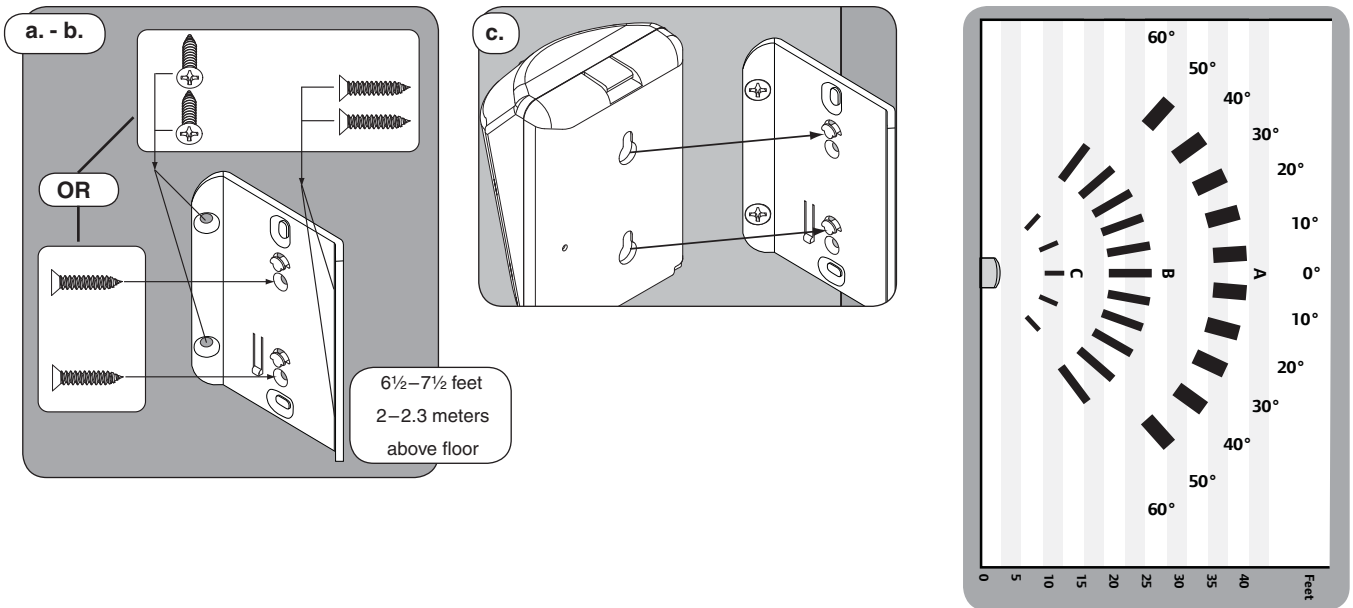

Solid areas on the Motion Sensor Coverage Area diagram (above) represent positive detection capability.

8

Motion Sensor Test and Operation

The Sensor detects and sends motion detected status to the Nexia Portal. (The Sensor is not intended to operate as a Z-Wave repeater.)

Before normal use, verify proper operation of the Motion Sensor.

- Clear the motion detection zone for 4 minutes.
- Move in the coverage area. Check that the LED on the Motion Sensor blinks once.
- When the sensor detects motion, it transmits a message to the Nexia Bridge and remains in an active state until no further motion occurs for a period of X minutes. (Any motion detected prior to X minutes will cause the detection timer to reset for another X minutes.) Check that the Nexia portal indicates a "motion detected" message. (Refer to the example below.)
- After X minutes with no motion detected, the Sensor will return to normal operation, and transmit a "normal operation" message to the Nexia Bridge. Check that the Nexia portal indicates normal operation.

Event History				
◆ Date	◆ Time	◆ User	◆ Device	◆ Event
02/15/2012	12:00 PM		New Sensor 4	ALARM 01 11
02/15/2012	11:30 AM		New Sensor 4	Closed
02/15/2012	11:30 AM		New Sensor 4	Opened

Maintenance

Change the Sensor Battery

When the Sensor indicates the battery is low, replace the battery as follows:

- a. Lift the tab on the top of the Sensor and pull forward to remove the cover. (See Step 1 for diagrams.)
- b. Remove the old battery.
- c. Insert a new 3V CR123A battery. Observe polarity.
- d. Replace the Sensor cover. (See Step 1 for diagrams.)

Note: Sensor enrollment is not required after battery change.



SAFETY HAZARD! BATTERY MAY EXPLODE IF NOT PROPERLY HANDLED.
DO NOT RECHARGE, DISASSEMBLE OR DISPOSE OF IN FIRE.

If necessary to remove a Sensor from the Nexia account, follow these steps to exclude the Sensor from a Z-Wave Network:

- a. Hold the Nexia Bridge within 6 feet (1.8 meters) of the Sensor during the entire exclusion process.
- b. Press and release the “-” button on the Bridge.
- c. Use a pin or paper clip to press the program button on the back of the Sensor case.
- d. Observe lights on the Bridge. The orange light will blink while exclusion is taking place. Exclusion is complete when the orange light becomes solid.
- e. Remove the battery from the Sensor after exclusion is complete.

For more information, refer to the Nexia Home Bridge Users Guide.

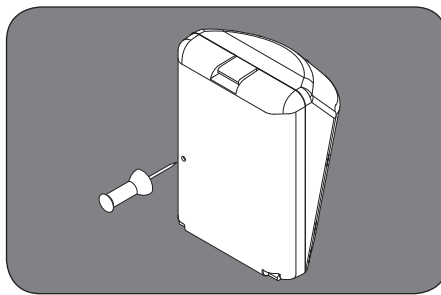
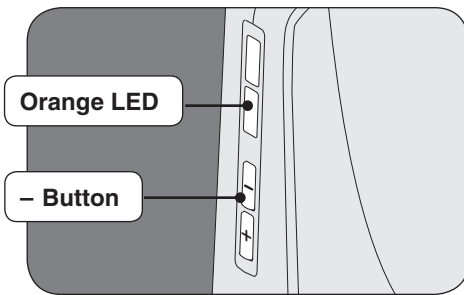

FCC Statement

This device complies with part 15 of the FCC rules. Operation is subject to the following two conditions: (1) This device may not cause harmful interference, and (2) this device must accept any interference received, including interference that may cause undesired operation.

Changes or modifications to this equipment not expressly approved by the party responsible for compliance could void the user's authority to operate the equipment.



nexiahome.com



U.S.A. /Canada
(877) 288-7707