

Wireless Control ZFM-80US/DA065 Z-Wave Fixture Switch Module

USER MANUAL

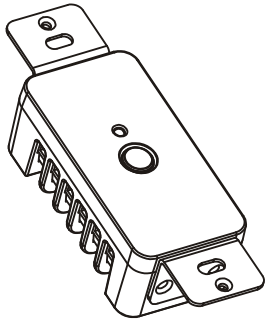

Introduction:

Thank you for choosing ZFM-80US Z-Wave control product. Our Z-Wave enabled product allows user to remotely control resistive household appliance, and make home control easy at low installation / maintenance cost. You may begin with a few Z-Wave enabled devices or build up a complete home automation system with our products.

The ZFM-80US Fixture Switch Module is a Z-Wave enabled device and fully compatible with any Z-Wave enabled network. It allows remote On/Off control of specified resistive household appliance. Each fixture switch module is designed to act as a repeater, which will re-transmit the RF signal to ensure that the signal is received by its intended destination by routing the signal around obstacle and radio dead spots.

Glossary

Device / Light / Node	Devices, lights and nodes are all terms to describe an individual Z-Wave device. These are all interchangeable when setting up your Z-Wave network.
Z-Wave Network	A collection of Z-Wave devices is controlled by primary and secondary controllers operating on the same system. A Z-Wave network has its own unique ID code so that controllers not in the network can not control the system.
Inclusion	Add a Z-Wave device to the network.
Exclusion	Delete a Z-Wave device from the network.
Network Wide Inclusion (NWI)	Network Wide Inclusion (NWI) enables both end-user friendly, Plug and Play like Z-Wave network installation as well as professional installation scenario where the inclusion process in terms of time will be reduced significantly. NWI is a feature supported by a new frame type named Explorer which enables the Z-Wave protocol to implement Adaptive Source Routing.
Association	Association is used to organize nodes in different groups allowing the device to identify the nodes by a group identifier. The groups can also be copied to other devices.

Key Features:

- High output power
- Remote ON/OFF control via the Z-Wave controller
- Manual ON/OFF control with the front panel push button
- Support External ON/OFF key connects to the module
- Advanced function
 - Conditional trigger for "Fail Safe Installation"
- Support Network Wide Inclusion (NWI) and Explore Frames
- Screw terminals for wires connection
- Flexible mounting structure - mount inside gang box or any place

Product Overview:

- A Mount
- B Status LED
- C ON/OFF/PROG Push button
- D External switch (S/W)
- E Z-Wave controlled output (isolated relay, RL)
- F AC input (L = terminal for Live lead; N = terminal for Neutral lead)

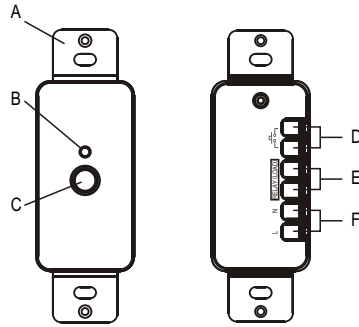

Installation:

DANGER! SHOCK HAZARD. Read and understand these instructions before installing. This device is intended for installation in accordance with the National Electric code and local regulations in the United States, or the Canadian Electrical Code and local regulations in Canada. It is recommended that a qualified electrician perform this installation.

For indoor use only in a dry location. Retain instructions for future use.

- Step 1 **WARNING:** To reduce the risk of fire or electric shock, install in a controlled environment relatively free of contaminants. To avoid fire, shock, or death; turn off power at circuit breaker or fuse and test that power is off before wiring!
- Step 2 **Identifying your wiring application:** refer to figure 1 and 2
NOTE: If the wiring in the wall box does not resemble any of above configurations, consult a qualified electrician.
- Step 3 **Connecting wires:** refer to figure 1 or 2 and connect the wires with correct symbols. Use at less 90° C copper wire only and the stripped wire end's length must be 9mm. The tightening torque must be 3.5lb-in. (Make sure all wires are firmly fixed at all terminals)

CAUTION : Risk of Electric Shock More than one disconnect switch may be required to de-energize the equipment before servicing.

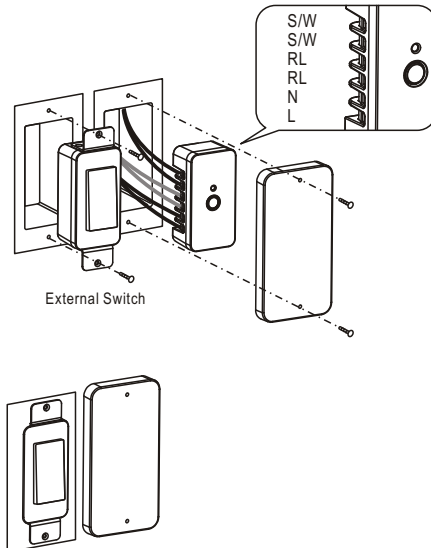

Single switch (connected with input AC power source for the load)

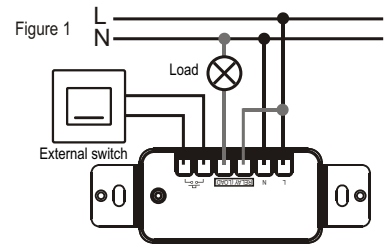

Single switch (connected with an external power source for the load)

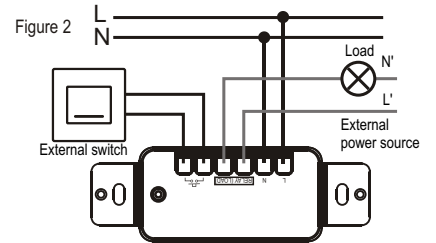

Warning

The resistive household appliance connected into the Z-Wave controlled outlet on this module must not exceed 230Vac 10A or 120Vac 15A.

External Switch

ZFM-80 provides an option to user that can add an external switch to control the On/Off function. ZFM-80US can be placed into the switch box with external wall switch cover. User can configure the external switch type through the configuration command

Configuration Command for External Switch

Parameter Number	Definitions
1 (0x01)	Set External switch type

Parameter Value	Definitions	Example:
0 (0x00)	Disable External switch	
1 (0x01)	Type A: Tact switch (normal open)	
2 (0x02)	Type B: Tact switch (normal close)	
3 (0x03)	Type C: Rocker switch (short = On; open = Off), default	
4 (0x04)	Type D: Rocker switch (short = Off, open = On)	

Advanced function "Conditional trigger for Fail Safe Installation"

ZFM-80US provides an advanced function "Conditional trigger for Fail Safe Installation". It can turn on or turn off the relay if ZFM-80US has not received any Z-Wave commands from a specified Z-Wave Node ID and within a specified period. For example: Z-Wave gateway can monitor a Z-Wave device status and power on equipment if this Z-Wave device is out of service.

Configuration Command for "Conditional trigger for Fail Safe Installation"

Parameter Number	Definitions	Parameter value range
2 (0x02)	Set timeout period	0 ~ 240 (minutes) (default value is 0 [function disabled])
3 (0x03)	Configure Node ID number for Z-Wave command source	1 ~ 232 (Node ID number) (default value is 0 [function disabled])
4 (0x04)	Set relay output status if timeout period has been reached	1 = turn on relay 0 = turn off relay (default value is 0)

LED Indication Status:

Operations	LED Indication Status	
	Device already exist in network	Device does NOT exist in network
ZFM-80US power on	<ul style="list-style-type: none"> LED flashes slowly within 2 seconds then stay on if external switch stay in active stage. LED light up. 	<ul style="list-style-type: none"> LED flashes slowly within 2 seconds then stay on if external switch stay in active stage. LED flashes slowly within 4 minutes then stay on if external switch stay in inactive stage.
Press PROG button / Press external switch (Learning mode)	LED flashes slowly within 2 seconds then stay on.	LED flashes slowly within 2 seconds then stay on.
Receive command / Send command or data	LED flashes 2 times then stay on.	N/A
Error	LED flashes 6 times rapidly then stay on.	N/A

Basic Operation

The connected device can be turned ON in two ways:

- Manual control with the push button on the ZFM-80US.
- Z-Wave remote controller.

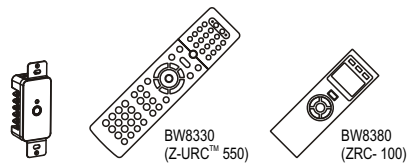

Manual ON/OFF function

Turn the resistive household appliance On/Off by pressing the button at front or external switch.

(Press the external switch to turn the resistive household appliance on if it is in off stage and vice versa)

Z-Wave Remote Control

Include or exclude the Fixture Switch Module from the existing Z-Wave home control network with your primary controller.

- Refer to your primary controller instructions to process the inclusion / exclusion setup procedure.
- When prompted by your primary controller, click once on the PROG button or external switch.
- The primary controller should indicate that the action was successful. If the controller indicates the action was unsuccessful, please repeat the procedure.
- Once the Fixture Switch Module is part of the network, the same basic procedure is used to add the Fixture Switch Module to groups or scenes. Refer to the primary controller's instructions for details.

Support Association Command Class

ZFM-80US support one association group, this association group contains 5 nodes max.

It is used to report the relay on/off status to specify nodes with ZFM-80US predefined association group once the relay state has been changed.

All On/All Off functions

Depending upon your primary controller, the Fixture Switch Module can be set to respond to ALL ON and ALL OFF commands up to four different ways. Some controllers may not be able to change the response from its default setting. Please refer to your controller's instructions for information on whether or not it supports the configuration function and if so, how to change this settings.

The four possible responses are:

- It will respond to ALL ON and the ALL OFF commands (default).
- It will not respond to ALL ON and ALLOFF commands.
- It will respond to the ALL OFF command but will not respond to the ALL ON command.
- It will respond to the ALL ON command but will not respond to the ALL OFF command.

Restoring Factory Defaults

All Configuration Parameters can be restored to their factory default settings by using your primary controller to reset the device. (Delete device from the network)

WIRELESS INFORMATION

Wireless range:

This device has an open-air line-of-sight transmission distance of 25m which complies with the Z-Wave standards. Performance can vary depending on the amount of objects in between Z-Wave devices such as walls and furniture. Every Z-Wave device set up in your network will act as a signal repeater allowing devices to talk to each other and find alternate routes in the case of a reception dead spot.

Radio frequency limitations:

- Each wall or object (i.e.: refrigerator, bookshelf, large TV, etc) can reduce the maximum range of 65 feet by up to 25 to 30%.
- Plasterboard and wooden walls block less of the radio signal than concrete, brick or tile walls which will have more of an effect on signal strength.
- Wall mounted Z-Wave devices will also suffer a loss of range if they are housed in metal junction boxes which could also reduce the range by up to 25 to 30%.

MAINTENANCE

- Do not expose your ZFM-80US to dust, strong sunlight, humidity, high temperatures or mechanical shocks.
- Do not use corrosive or abrasive cleansers on your ZFM-80US.
- Keep the unit dust free by wiping it with a soft, dry cloth.
- Do not disassemble your ZFM-80US, it contains no user-serviceable parts.

TECHNICAL SPECIFICATIONS

Model no.	ZFM-80US / DA065
RF frequency	908.42MHz
Input voltage	120Vac or 230Vac
RF operating distance	up to 25m (line of sight between the Wireless Controller and the closest Z-Wave receiver module.)
Z-Wave association group	Support 1 association group; Each association group contains 5 nodes max.
Output relay power rating	230Vac 10A max. or 120Vac 15A max. (Resistive load)
Dimension	68(L) x 35(W) x 25(H)mm
Weight	50g metal mount excluded; 70g metal mount included
Storage	-25~60°C
Operation Temperature	-5~45°C
Environment	Indoor use only

Note: Specifications subject to change without notice due to continuing product improvement

Certifications

FCC Information

FCC ID : ZGIDA065

This device complies with Part 15 of the FCC Rules.

Operation is subject to the following two conditions:

- this device may not cause harmful interference, and
- this device must accept any interference received, including interference that may cause undesired operation.

Warning:

Changes or modifications to this unit not expressly approved by the party responsible for compliance could void the user authority to operate the equipment.

NOTE:

This equipment has been tested and found to comply with the limits for a Class B digital device, pursuant to Part 15 of the FCC Rules. These limits are designed to provide reasonable protection against harmful interference in a residential installation. This equipment generates, uses and can radiate radio frequency energy and, if not installed and used in accordance with the instructions, may cause harmful interference to radio communications.

However, there is no guarantee that interference will not occur in a particular installation. If this equipment does cause harmful interference to radio or television reception, which can be determined by turning the equipment off and on, the user is encouraged to try to correct the interference by one or more of the following measures:

- Reorient or relocate the receiving antenna.
- Increase the separation between the equipment and receiver.
- Connect the equipment into an outlet on a circuit different from that to which the receiver is connected.
- Consult the dealer or an experienced radio/TV technician for help.

IC information

IC : 9548A-DA065

This device complies with Industry Canada licence-exempt RSS standard(s). Operation is subject to the following two conditions:

- this device may not cause interference, and
- this device must accept any interference, including interference that may cause undesired operation of the device.

This device complies with RSS-310 of Industry Canada. Operation is subject to the condition that this device does not cause harmful interference.

WARNINGS

Do not dispose of electrical appliances as unsorted municipal waste, use separate collection facilities. Contact your local government for information regarding the collection systems available.

RISK OF FIRE

RISK OF ELECTRICAL SHOCK

RISK OF BURNS

DID NOT QUALIFY FOR INSTRUMENT OF MEDICAL AND LIFE SUPPORT EQUIPMENT

Z-Wave Fixture Switch Module never got qualified certificate to supply power for medical instrument or any life support equipment.

There is no user serviceable parts in the Fixture Switch Module.

Please contact a qualified electrician to install this product. Do not modify the fixture switch module in any way.

WARRANTY

ONE-YEAR LIMITED WARRANTY: Remotec warrants this product to be free from defects in materials and workmanship under normal use and service for a period of one year from the original date of purchase from the distributor or dealer.

REMOTEC shall not be liable for:

- Damages caused by defective devices for indirect, incidental, special, consequential or punitive damages, including, inter alia, loss of profits, savings, data, loss of benefits, claims by third parties and any property damage or personal injuries arising from or related to the use of the device.
- Service trips to provide instruction on product use.
- Shipping costs for replacement products.

This warranty is limited to the repair or replacement of this product only, if the purchase date cannot be substantiated, the warranty period will begin on the date of manufacture as indicated on this product. All warranty claims must be made to Remotec appointed distributors or dealers during the applicable warranty period. This warranty gives you specific legal right and you may also have other rights which vary in each country.